

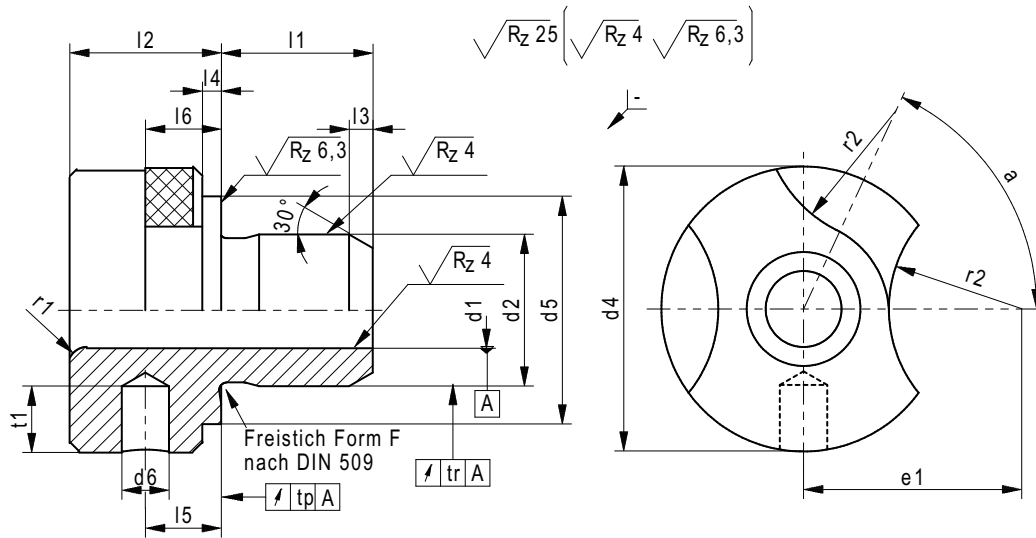

# Steckbohrbüchsen

DIN 173 K / L



d <sub>1</sub> - F7		Abstufung	d <sub>2</sub> m6	l <sub>1</sub>			d <sub>4</sub>	d <sub>5</sub> 0 -0,25	d <sub>6</sub> H7	l <sub>2</sub>	l <sub>3</sub>
über	bis			kurz	mittel	lang					
1,0	4,0	Bohrung d <sub>1</sub> gestuft < 15 mm, 0,1 mm und 0,25 mm > 15 mm, vorzugsweise 0,5 mm	8	10	16	-	15	12	2,5	8	1,25
4,0	6,0		10	12	20	25	18	15			
6,0	8,0		12	16	28	36	22	18	3	10	1,5
8,0	10,0		15	20	36	45	26	22			
10,0	12,0		18	25	45	56	30	26	5	12	2,5
12,0	15,0		22	30	56	67	34	30			
15,0	18,0		26	36	67	-	39	35	6	12	3
18,0	22,0		30	42	-	-	46	42			
22,0	26,0		35	-	-	-	52	46	-	-	-
26,0	30,0		42	-	-	-	59	53	-	-	-

d <sub>1</sub> - F7		l <sub>4</sub> 0 -0,25	l <sub>5</sub>	l <sub>6</sub> 0 -0,2	e <sub>1</sub>	r <sub>1</sub>	r <sub>2</sub> +0,5 -0,2	a	t <sub>1</sub>	t <sub>r</sub>	t <sub>p</sub>						
über	bis																
1,0	4,0	1	4,25	3	11,5	1,5	7	65°	4	0,02	0,005						
4,0	6,0											6	4	13,0	2	8,5	60°
6,0	8,0																
8,0	10,0		7	5,5	18,0	3	10,5	35°									
10,0	12,0								7	5,5	20,0	3	10,5	30°			
12,0	15,0		7	5,5	23,5	3	10,5	30°									
15,0	18,0								7	5,5	26,0	3	10,5	30°			
18,0	22,0		7	5,5	29,5	3	10,5	30°									
22,0	26,0								1,5	7	32,5	3	10,5	30°			
26,0	30,0		1,5	7	36,0	3	10,5	30°									

**Werkstoff:** 100 Cr6 oder ähnlich  
**Härte:** 740 + 80 HV durchgehärtet  
**Bestellbeispiel:** DIN 173 K d<sub>1</sub> x l<sub>1</sub>, DIN 173 K 8,0 x 20



## MAKE AG

Bohrbüchsen und Normteile  
 Schützenstrasse 19 / Postfach 192  
 CH-3627 Heimberg  
 Tel: +41 (0)33 439 80 80 Fax +41 (0)33 439 80 81  
 info@make-ag.ch / www.make-ag.ch