

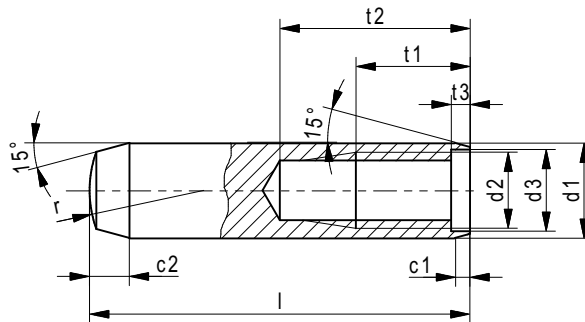

Zylinderstifte

DIN 7979



d ₁ -m6	6	8	10	12	16	18	20
d ₂	M4	M5	M6	M6	M8	M10	M10
d ₃	4,3	5,3	6,3	6,3	8,3	10,3	10,3
t ₁	6	8	10	12	16	20	20
t ₂	10	13	16	18	23	27	27
t ₃	1	1,2	1,2	1,2	1,6	1,6	1,6
c ₁	0,8	1	1,2	1,6	1,8	2	2,5
c ₂	2,1	2,6	3	3,8	4	4,7	6
r	6	10	10	14	16	20	20
Länge l							
16	x						
18	x						
20	x	x					
24	x	x	x				
28	x	x	x				
32	x	x	x	x	x		
36	x	x	x	x	x		
40	x	x	x	x	x		
45	x	x	x	x	x		
50	x	x	x	x	x	x	x
55	x	x	x	x	x	x	x
60	x	x	x	x	x	x	x
70		x	x	x	x	x	x
80		x	x	x	x	x	x
90			x	x	x	x	x
100			x	x	x	x	x
120				x	x	x	x
Werkstoff:	100 Cr6 oder ähnlich						
Härte:	680 + 100 HV durchgehärtet						
Ausführung:	Mit Luftentweichungsfläche						
Bestellbeispiel:	DIN 7979 d ₁ x l, DIN 7979 16 x 60						



MAKE AG

Bohrbüchsen und Normteile
 Schützenstrasse 19 / Postfach 192
 CH-3627 Heimberg
 Tel: +41 (0)33 439 80 80 Fax +41 (0)33 439 80 81
 info@make-ag.ch / www.make-ag.ch